

CROFT, LLC

SERIES 9100 WOODBUCK MULLION AND SERIES 9100 HEAVY-DUTY MULLION (HORIZONTAL) (WZ3)(IMPACT)

NOTES:

- THE PRODUCT SHOWN HEREIN IS DESIGNED AND MANUFACTURED TO COMPLY WITH THE 7TH EDITION FBC, SECTION 1709.8.
- MULLION INSTALLATION DETAILS APPLY TO EXTRUDED MULLIONS WITH EXTRUDED ALUMINUM ANCHOR CLIP WHEN USED TO MULL WINDOWS SIDE BY SIDE
- APPROVED IMPACT PROTECTIVE SYSTEM IS NOT REQUIRED ON THESE PRODUCTS IN WIND BORNE DEBRIS REGIONS ZONE 3 OR LESS SUCH THAT ADJOINING WINDOWS ARE IMPACT RATED.
- APPROVED IMPACT PROTECTIVE SYSTEM IS REQUIRED ON THESE PRODUCTS IN WIND BORNE DEBRIS REGION ZONE 4.
- USE TWO (2) #10 WOOD SCREWS, PER CLIP, OF SUFFICIENT LENGTH TO ACHIEVE MINIMUM EMBEDMENT OF 1 1/2" INTO WOOD FRAMING. (SEE INSTALLATION DETAILS ON SHEET 2).
- USE TWO (2) 3/16" ITW TAPCONS, PER CLIP, OF SUFFICIENT LENGTH TO ACHIEVE MINIMUM EMBEDMENT OF 1 3/4" INTO CONCRETE OR 1" WHEN INTO HOLLOW BLOCK CMU. (SEE INSTALLATION DETAILS ON SHEET 2).
- USE ONE (1) 1/4" ITW TAPCON, PER CLIP, OF SUFFICIENT LENGTH TO ACHIEVE MINIMUM EMBEDMENT OF 1 3/4" WHEN ANCHORED INTO CONCRETE.
- USE TWO (2) #10-16 SELF-DRILLING SCREWS, PER CLIP, OF SUFFICIENT LENGTH TO ACHIEVE A MINIMUM 3 THREADS PENETRATION BEYOND STEEL SUBSTRATE. (SEE INSTALLATION DETAILS ON SHEET 2).
- 2X WOOD BUCKS AND STEEL STUDS TO BE DESIGNED AND ANCHORED TO PROPERLY TRANSFER ALL LOADS TO STRUCTURE AND IS THE RESPONSIBILITY OF THE ARCHITECT OR ENGINEER OF RECORD.
- SEE CHARTS & NOTES ON SHEETS 3-5 FOR DESIGN PRESSURE RATINGS.
- THIS MULLION IS ONLY VALID WHEN USED IN CONJUNCTION WITH ALL APPLICABLE CROFT, LLC PRODUCTS.
- ALL WINDOWS USED WITH THIS MULLION SHALL BE QUALIFIED UNDER SEPARATE APPROVAL. THE LESSER DESIGN PRESSURE RATING OF THE WINDOW OR THE MULLION OF INSTALLATION SHALL GOVERN THE OVERALL DESIGN PRESSURE OF THE ASSEMBLY.
- MULLION MATERIAL: 6063-T5 ALUMINUM.
- CLIP MATERIAL: 6063-T5 ALUMINUM.
- INSTALLATION ANCHOR CAPACITIES FOR PRODUCTS HEREIN ARE BASED ON SUBSTRATE MATERIALS WITH THE FOLLOWING PROPERTIES:
 - WOOD - MINIMUM SPECIFIC GRAVITY OF 0.55.
 - CONCRETE - MINIMUM COMPRESSIVE STRENGTH OF 3000 PSI.
 - CMU - SHALL CONFORM TO MINIMUM REQUIREMENTS OF ASTM C90
 - STEEL - MINIMUM YIELD STRENGTH OF 33 KSI. MINIMUM 18 GA. WALL THICKNESS.

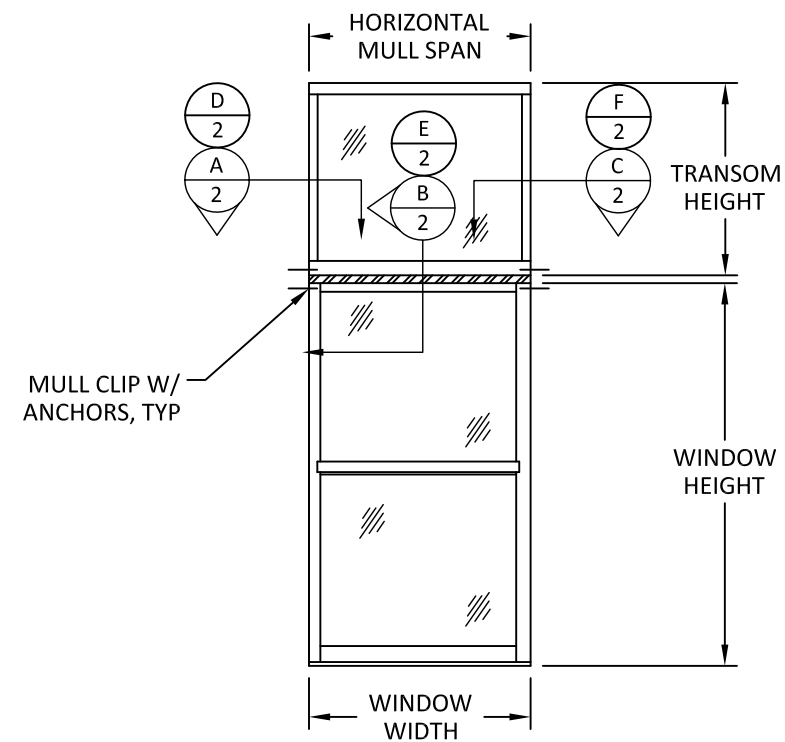

HORIZONTAL MULLION FOR STACKED WINDOWS

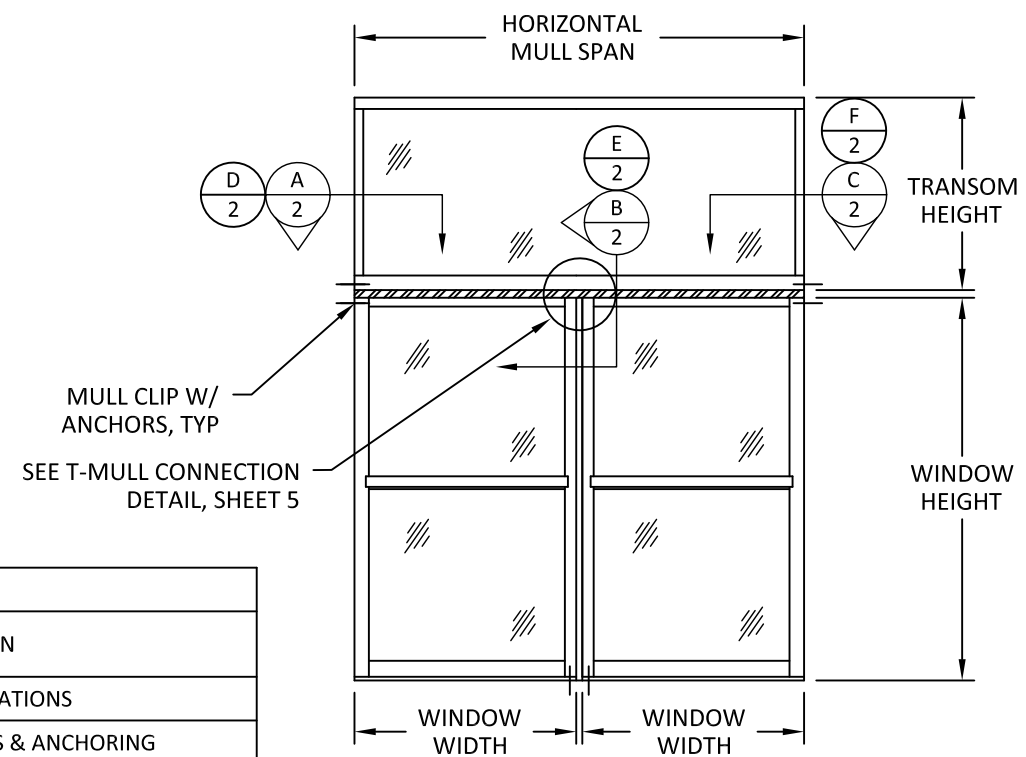

HORIZONTAL MULLION FOR T-MULL CONFIGURATION

TABLE OF CONTENTS	
SHEET	SHEET DESCRIPTION
1	GENERAL NOTES & ELEVATIONS
2	MULLION INSTALLATION DETAILS & ANCHORING
3	SERIES 9100 WOODBUCK MULL DP CHART & DETAILS
4	SERIES 9100 MULLION-HEAVY DUTY DP CHART & DETAIL
5	SERIES 9100 MULL-HEAVY DUTY T-MULL DP CHART & DETAILS



P.O. BOX 826
MCCOMB, MS 39649
PH.: 601-684-6121 FX: 601-783-3188

TITLE: SERIES 9100 HORIZONTAL MULLIONS (WZ3)(IMPACT)
GENERAL NOTES AND ELEVATIONS

PREPARED BY: BUILDING DROPS, INC.
398 E. DANIA BEACH BLVD., STE. 338
DANIA BEACH, FL 33004
PH: (954)399-8478
FAX: (954)744-4738
WEB: www.buildingdrops.com

REMARKS	BY	DATE
MULLS & CLIPS REV.	MTJ	6/13
FBC 2014 UPDATE	SM	9/14
FBC 2017 UPDATE	HR	6/17
FBC 2020 UPDATE	LL	6/21

THE INSTALLATION DETAILS DESCRIBED HEREIN ARE GENERIC AND MAY NOT REFLECT ACTUAL CONDITIONS FOR A SPECIFIC SITE. IF SITE CONDITIONS CAUSE INSTALLATION TO DEVIATE FROM THE REQUIREMENTS DETAILED HEREIN, A LICENSED ENGINEER OR ARCHITECT SHALL PREPARE SITE SPECIFIC DOCUMENTS FOR USE WITH THIS DOCUMENT.

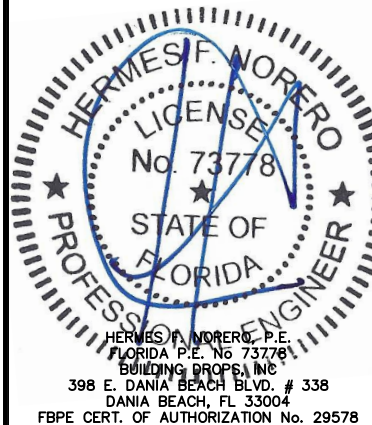

FL #: **FL15527**

DATE: **04.18.12**

DWG. BY: **MSS** CHK. BY: **HFN**

SCALE: **NTS**

DWG. #: **CRF012**

SHEET **1**



P.O. BOX 826
MCCOMB, MS 39649
PH.: 601-684-6121 FX: 601-783-3188

TITLE: **SERIES 9100 HORIZONTAL MULLIONS (WZ3)/(IMPACT)**
MULLION INSTALLATION DETAILS & ANCHORING

PREPARED BY: **BUILDING DROPS, INC.**
398 E. DANIA BEACH BLVD., STE. 338
DANIA BEACH, FL 33004
PH: (954)399-8478
FAX: (954)744-4738
WEB: www.buildingdrops.com

REMARKS	BY	DATE
MULLS & CLIPS REV.	MTJ	6/13
FBC 2014 UPDATE	SM	9/14
FBC 2017 UPDATE	HR	6/17
FBC 2020 UPDATE	LL	6/21

THE INSTALLATION DETAILS DESCRIBED HEREIN ARE GENERIC AND MAY NOT REFLECT ACTUAL CONDITIONS FOR A SPECIFIC SITE. IF SITE CONDITIONS CAUSE INSTALLATION TO DEVIATE FROM THE REQUIREMENTS DETAILED HEREIN, A LICENSED ENGINEER OR ARCHITECT SHALL PREPARE SITE SPECIFIC DOCUMENTS FOR USE WITH THIS DOCUMENT.

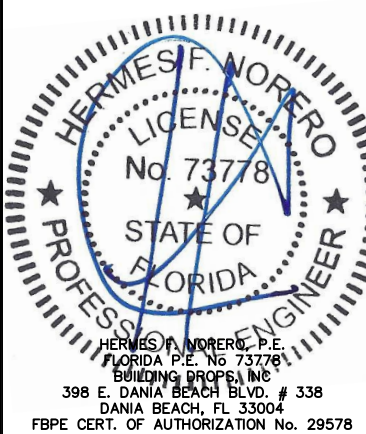

FL #: **FL15527**

DATE: **04.18.12**

DWG. BY: **MSS** CHK. BY: **HFN**

SCALE: **NTS**

DWG. #: **CRF012**

SHEET

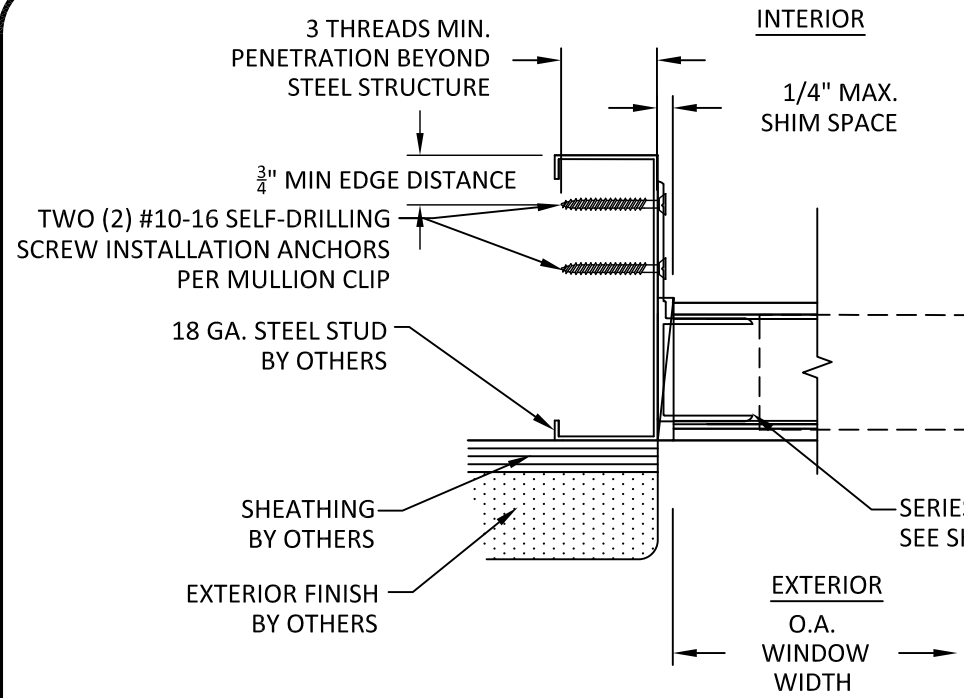

A
2 **HORIZONTAL SECTION**
JAMB - STEEL STUD TYP.
SERIES 9100 WOODBUCK MULL

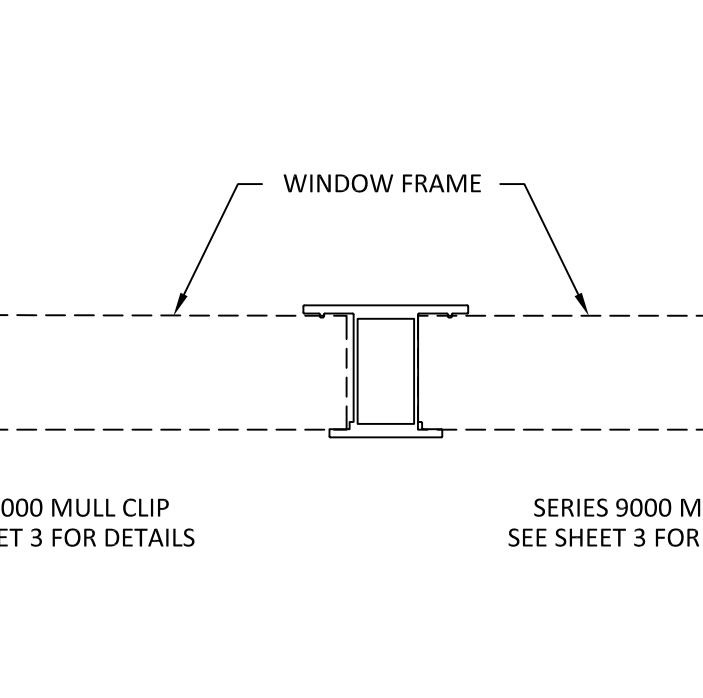

B
2 **VERTICAL SECTION**
SERIES 9100 WOODBUCK MULL

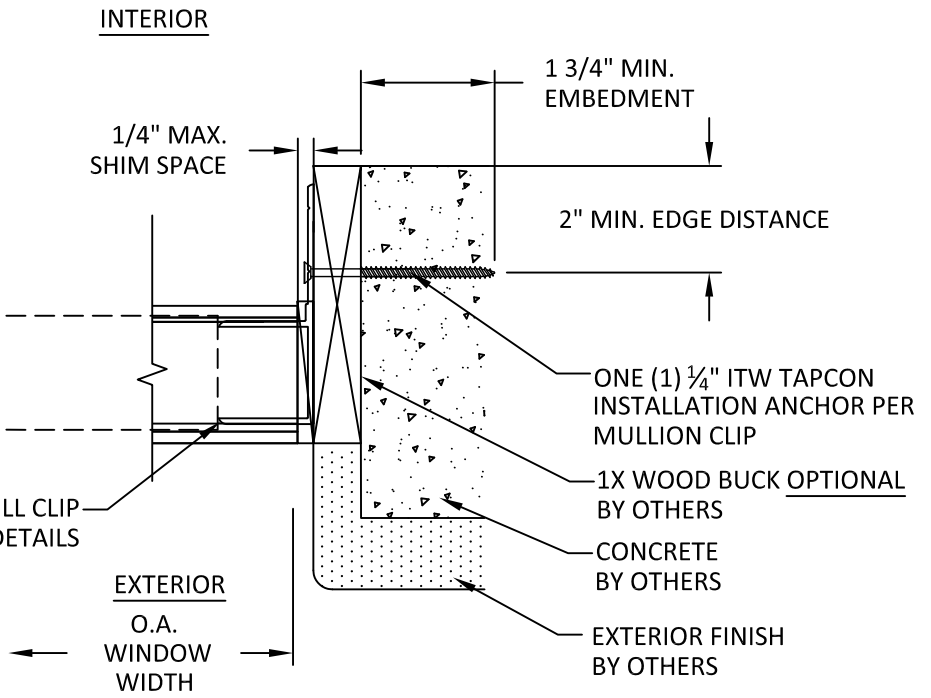

C
2 **HORIZONTAL SECTION**
JAMB - 1X/CONCRETE TYP.
SERIES 9100 WOODBUCK MULL

NOTE:
INSTALLATION DETAILS SHOWN ARE GENERIC & ARE FOR ILLUSTRATION PURPOSES. INSTALLATION CONDITIONS SHOWN MAY BE USED WITH ANY MULLION DESCRIBED HEREIN.

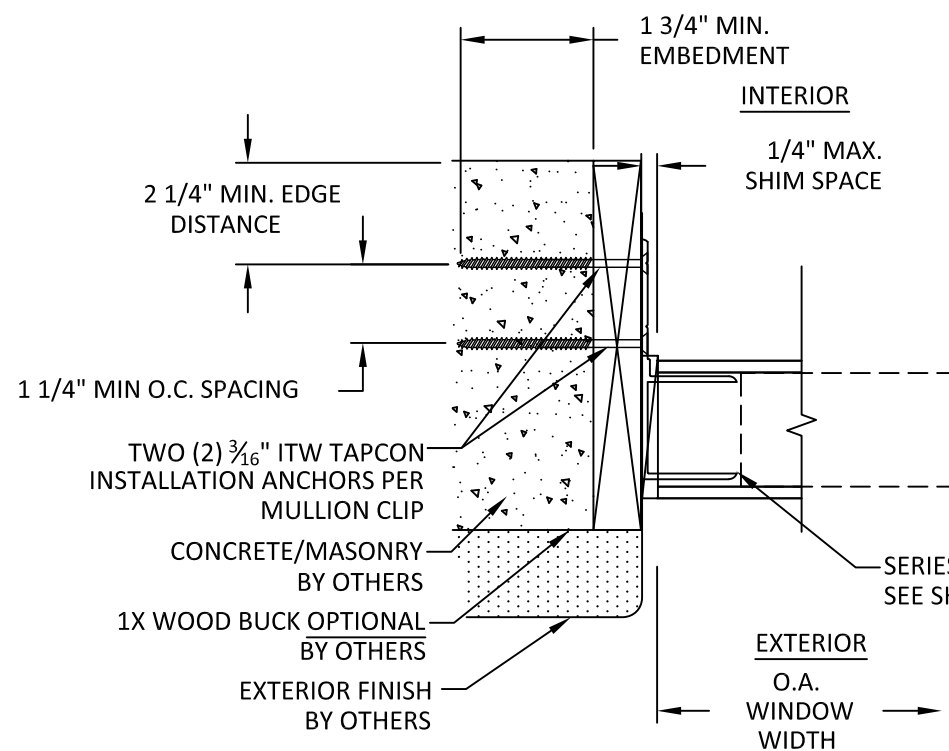

D
2 **HORIZONTAL SECTION**
JAMB - 1X/CONCRETE/MASONRY TYP.
SERIES 9100 MULL-HEAVY DUTY

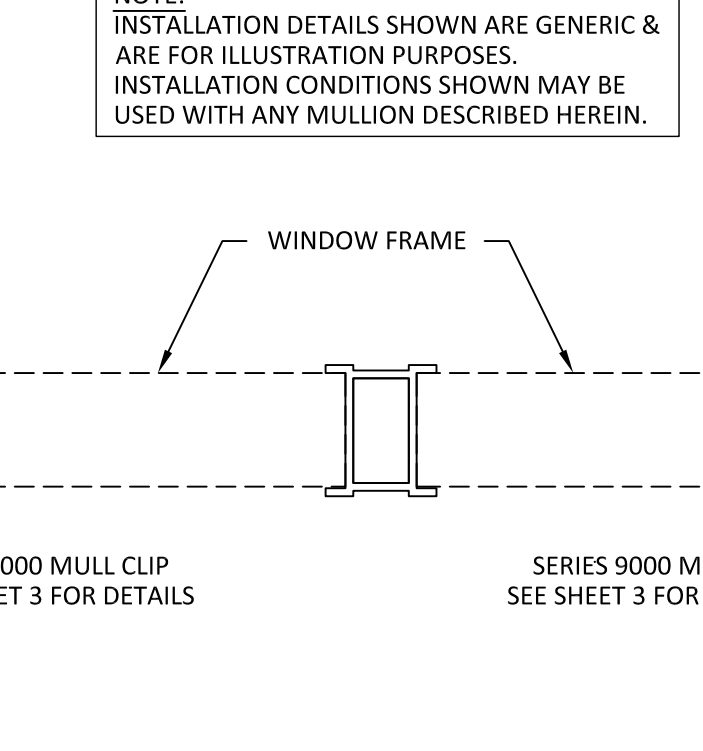

E
2 **VERTICAL SECTION**
SERIES 9100 MULL-HEAVY DUTY

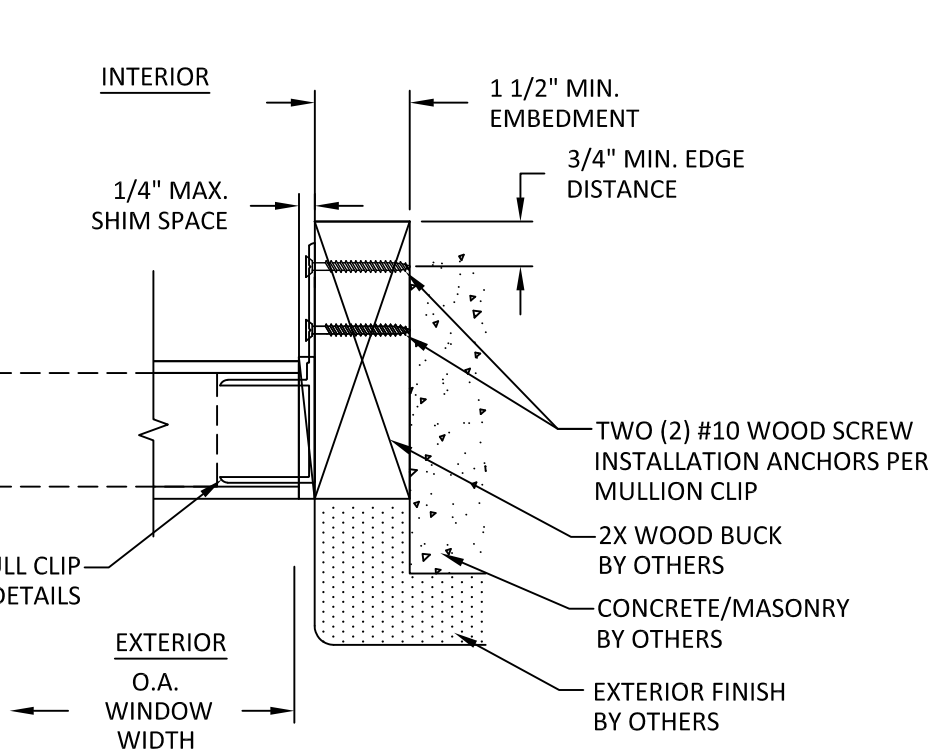

F
2 **HORIZONTAL SECTION**
JAMB - 2X WOOD BUCK TYP.
SERIES 9100 MULL-HEAVY DUTY

7/12/2021 9:32 AM s:\projects\croft lic\lbc-21-0656 - fbc submittal - revision series 9000 aluminum mullions\dwg\crf012.dwg

7/12/2021 9:32 AM

s:\projects\croat lic\fbc-21-0656 - fbc submittal - revision series 9100 aluminum mullions\dwg\crf012.dwg

SERIES 9100 MULLION-HEAVY DUTY DESIGN PRESSURE CHARTS

Maximum design pressure capacity chart

Series 9100 Horizontal Mullion - Heavy Duty - Stacked Windows

Design pressures are limited either by mullion or anchor screw or anchor clip capacity.

Height (in)		Unit width (in)									
Window	Transom	24.0	27.0	30.0	33.0	36.0	39.0	42.0	45.0	48.0	
24.0	12.0	150.0	150.0	150.0	150.0	150.0	146.6	124.6	107.3	93.5	
30.0	15.0	150.0	150.0	150.0	150.0	150.0	124.6	105.0	89.7	77.7	
36.0	18.0	150.0	150.0	150.0	150.0	138.5	112.5	93.5	79.1	68.0	
42.0	21.0	150.0	150.0	150.0	150.0	131.6	106.3	87.2	72.8	61.9	
48.0	24.0	150.0	150.0	150.0	150.0	126.2	101.7	83.4	69.4	58.4	
54.0	27.0	150.0	150.0	150.0	150.0	122.1	98.2	80.4	66.8	56.2	
60.0	30.0	150.0	150.0	150.0	150.0	119.2	95.4	77.9	64.6	54.3	
66.0	33.0	150.0	150.0	150.0	150.0	117.4	93.5	76.0	62.9	52.8	
72.0	36.0	150.0	150.0	150.0	150.0	116.8	92.3	74.7	61.5	51.5	
78.0	39.0	150.0	150.0	150.0	150.0	116.8	91.9	73.9	60.6	50.5	
84.0	42.0	150.0	150.0	150.0	150.0	116.8	91.9	73.6	60.0	49.9	
90.0	45.0	150.0	150.0	150.0	150.0	116.8	91.9	73.6	59.8	49.4	
96.0	48.0	150.0	150.0	150.0	150.0	116.8	91.9	73.6	59.8	49.3	

NOTES FOR SERIES 9100 MULLION-HEAVY DUTY FOR STACK WINDOW AND MULLION CLIP INSTALLATIONS

- THE DESIGN PRESSURES IN THIS CHART ARE FOR THE MULLIONS LISTED ABOVE WHEN USED WITH THE CLIP LISTED ABOVE.
- FOR HORIZONTAL MULL CLIPS IN WOOD FRAMING INSTALLATION USE TWO (2) #10 WOOD SCREWS AT EACH MULLION CLIP. ANCHORS MUST BE OF SUFFICIENT LENGTH TO ACHIEVE A 1 1/2" MINIMUM EMBEDMENT INTO FRAMING. SEE SHEET 2 FOR DETAILS.
- FOR HORIZONTAL MULL CLIPS IN STEEL FRAME INSTALLATION, USE (2) TWO #10-16 SELF-DRILLING SCREWS AT EACH ANCHOR CLIP WITH SUFFICIENT LENGTH TO ACHIEVE A MINIMUM 3 THREAD PENETRATION BEYOND STEEL SUBSTRATE. SEE SHEET 2 FOR DETAILS.
- FOR HORIZONTAL MULL CLIPS IN CONCRETE OR CMU INSTALLATION USE TWO (2) 3/16" ITW TAPCONS AT EACH MULLION CLIP. ANCHORS MUST BE OF SUFFICIENT LENGTH TO ACHIEVE A 1" MINIMUM EMBEDMENT INTO CMU (HOLLOW BLOCK) OR 1 3/4" EMBEDMENT INTO CONCRETE. SEE SHEET 2 FOR DETAILS. FOR ALTERNATE INSTALLATION TO CONCRETE, SEE NOTE 5 BELOW.
- FOR HORIZONTAL MULL CLIPS IN CONCRETE INSTALLATION USE ONE (1) 1/4" ITW TAPCON AT EACH MULLION CLIP. ANCHORS MUST BE OF SUFFICIENT LENGTH TO ACHIEVE A 1 3/4" EMBEDMENT INTO CONCRETE. SEE SHEET 2 FOR DETAILS.
- CHART APPLIES ONLY TO SERIES 9100 HEAVY DUTY MULLION AS SPECIFIED ABOVE WHEN USED TO MULL WINDOWS STACKED ONE ABOVE THE OTHER.
- READ WINDOW HEIGHT AND MULL SPAN IN INCHES. DESIGN PRESSURE VALUES ON THIS CHART ARE POSITIVE AND NEGATIVE POUNDS PER SQUARE FOOT (PSF).
- DESIGN PRESSURE VALUES APPLY TO MULLION WHERE TWO OR MORE WINDOWS ARE LISTED IN A SINGLE OPENING. LESSER DESIGN PRESSURE OF INDIVIDUAL WINDOW OR MULLION OF INSTALLATION SHALL GOVERN.
- REFER TO EVALUATION REPORT# 7647 FOR MORE MULLION SPECIFICATIONS.

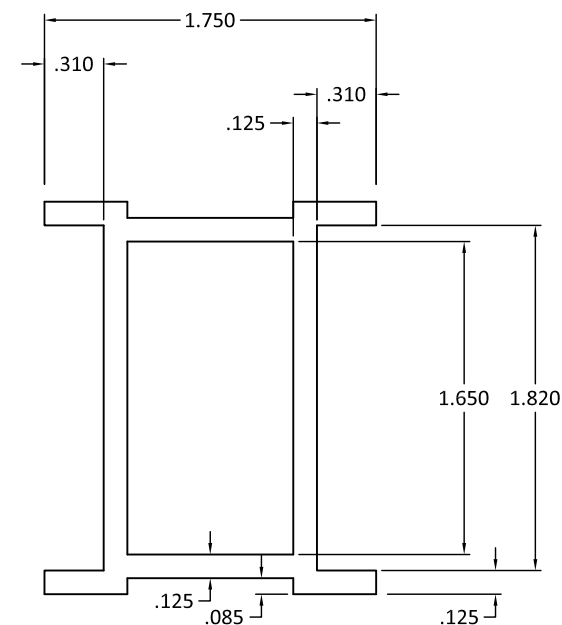

SERIES 9100 MULLION-HEAVY DUTY DETAIL



P.O. BOX 826
MCCOMB, MS 39649
PH.: 601-684-6121 FX: 601-783-3188

TITLE: SERIES 9100 HORIZONTAL MULLIONS (WZ3)/(IMPACT) SERIES 9100 MULLION-HEAVY DUTY DP CHART & DETAIL

PREPARED BY: BUILDING DROPS, INC.
398 E. DANIA BEACH BLVD., STE. 338
DANIA BEACH, FL 33004
PH: (954)399-8478
FAX: (954)744-4738
WEB: www.buildingdrops.com

REMARKS	BY	DATE
MULLS & CLIPS REV.	MTJ	6/13
FBC 2014 UPDATE	SM	9/14
FBC 2017 UPDATE	HR	6/17
FBC 2020 UPDATE	LL	6/21

THE INSTALLATION DETAILS DESCRIBED HEREIN ARE GENERIC AND MAY NOT REFLECT ACTUAL CONDITIONS FOR A SPECIFIC SITE. IF SITE CONDITIONS CAUSE INSTALLATION TO DEVIATE FROM THE REQUIREMENTS DETAILED HEREIN, A LICENSED ENGINEER OR ARCHITECT SHALL PREPARE SITE SPECIFIC DOCUMENTS FOR USE WITH THIS DOCUMENT.

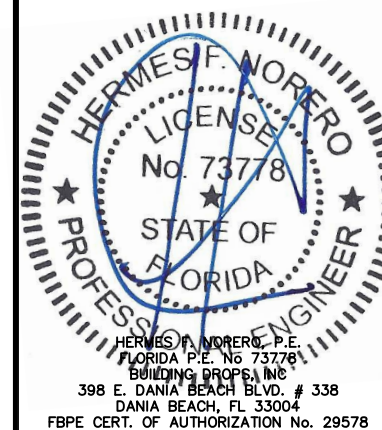

FL #:	FL15527
DATE:	04.18.12
DWG. BY:	MSS
CHK. BY:	HFN
SCALE:	NTS
DWG. #:	CRF012

SHEET **4**



P.O. BOX 826
MCCOMB, MS 39649
PH.: 601-684-6121 FX: 601-783-3188

SERIES 9100 MULLION-HEAVY DUTY DESIGN PRESSURE CHARTS

Maximum design pressure capacity chart (psf)

Series 9100 Horizontal Mullion - Heavy Duty - T-Mullion Configuration

Design pressures are limited either by mullion or anchor screw or anchor clip capacity.

Window Transom	Height (in)		Unit width (in)																
	24.0	27.0	24.0	27.0	30.0	33.0	36.0	39.0	42.0	45.0	48.0	54.0	60.0	66.0	72.0	78.0	84.0	90.0	96.0
24.0	12.0	150.0	150.0	150.0	150.0	150.0	150.0	150.0	142.4	130.6	120.4	104.0	91.5	80.2	67.2	57.1	49.2	42.8	37.5
30.0	15.0	150.0	150.0	150.0	150.0	145.8	132.0	120.4	110.5	101.9	88.0	77.0	64.7	54.2	46.0	39.6	34.4	30.2	
36.0	18.0	150.0	150.0	150.0	141.7	127.1	115.0	104.9	96.2	88.8	76.7	66.0	54.3	45.5	38.6	33.2	28.8	25.3	
42.0	21.0	150.0	150.0	143.0	126.5	113.3	102.4	93.4	85.7	79.0	68.3	57.1	46.9	39.2	33.3	28.6	24.9	21.8	
48.0	24.0	150.0	149.8	130.2	115.0	102.8	92.8	84.5	77.5	71.5	61.7	50.4	41.4	34.6	29.3	25.2	21.9	19.2	
54.0	27.0	150.0	139.0	120.4	106.0	94.6	85.3	77.5	71.0	65.5	56.3	45.2	37.1	31.0	26.3	22.5	19.6	17.1	
60.0	30.0	150.0	130.6	112.6	98.8	88.0	79.2	71.9	65.8	60.6	51.2	41.1	33.7	28.1	23.8	20.4	17.7	15.5	
66.0	33.0	148.2	124.0	106.4	93.1	82.6	74.2	67.3	61.5	56.6	47.0	37.7	30.9	25.7	21.8	18.7	16.2	14.2	
72.0	36.0	143.0	118.7	101.4	88.3	78.2	70.1	63.4	57.9	53.2	43.6	34.9	28.5	23.8	20.1	17.2	14.9	13.1	
78.0	39.0	139.2	114.6	97.3	84.5	74.5	66.6	60.2	54.8	50.3	40.6	32.5	26.5	22.1	18.7	16.0	13.9	12.1	
84.0	42.0	136.6	111.5	94.1	81.3	71.5	63.7	57.5	52.3	47.9	38.1	30.4	24.9	20.7	17.5	15.0	13.0	11.3	
90.0	45.0	135.0	109.2	91.5	78.7	68.9	61.3	55.1	50.0	45.8	36.0	28.7	23.4	19.5	16.4	14.1	12.2	10.6	
96.0	48.0	134.5	107.6	89.5	76.5	66.8	59.2	53.1	48.1	44.0	34.1	27.1	22.1	18.4	15.5	13.3	11.5	10.0	

NOTES FOR SERIES 9100 MULLION-HEAVY DUTY FOR T-MULLION CONFIGURATIONS AND MULLION CLIP INSTALLATIONS

- THE DESIGN PRESSURES IN THIS CHART ARE FOR THE MULLIONS LISTED ABOVE WHEN USED WITH THE CLIP LISTED ABOVE.
- FOR HORIZONTAL MULL CLIPS IN WOOD FRAMING INSTALLATION USE TWO (2) #10 WOOD SCREWS AT EACH MULLION CLIP. ANCHORS MUST BE OF SUFFICIENT LENGTH TO ACHIEVE A 1 1/2" MINIMUM EMBEDMENT INTO FRAMING. SEE SHEET 2 FOR DETAILS.
- FOR HORIZONTAL MULL CLIPS IN STEEL FRAME INSTALLATION, USE (2) TWO #10-16 SELF-DRILLING SCREWS AT EACH ANCHOR CLIP WITH SUFFICIENT LENGTH TO ACHIEVE A MINIMUM 3 THREAD PENETRATION BEYOND STEEL SUBSTRATE. SEE SHEET 2 FOR DETAILS.
- FOR HORIZONTAL MULL CLIPS IN CONCRETE OR CMU INSTALLATION USE TWO (2) 3/16" ITW TAPCONS AT EACH MULLION CLIP. ANCHORS MUST BE OF SUFFICIENT LENGTH TO ACHIEVE A 1" MINIMUM EMBEDMENT INTO CMU (HOLLOW BLOCK) OR 1 3/4" EMBEDMENT INTO CONCRETE. SEE SHEET 2 FOR DETAILS. FOR ALTERNATE INSTALLATION TO CONCRETE, SEE NOTE 5 BELOW.
- FOR HORIZONTAL MULL CLIPS IN CONCRETE INSTALLATION USE ONE (1) 1/4" ITW TAPCON AT EACH MULLION CLIP. ANCHORS MUST BE OF SUFFICIENT LENGTH TO ACHIEVE A 1 3/4" EMBEDMENT INTO CONCRETE. SEE SHEET 2 FOR DETAILS.
- CHART APPLIES ONLY TO SERIES 9100 MULLION-HEAVY DUTY AS SPECIFIED ABOVE WHEN USED TO MULL TRANSOM WINDOWS STACKED ABOVE TWIN WINDOWS IN T-MULLION CONFIGURATION.
- READ WINDOW HEIGHT AND MULL SPAN IN INCHES. DESIGN PRESSURE VALUES ON THIS CHART ARE POSITIVE AND NEGATIVE POUNDS PER SQUARE FOOT (PSF).
- DESIGN PRESSURE VALUES APPLY TO MULLION WHERE TWO OR MORE WINDOWS ARE LISTED IN A SINGLE OPENING. LESSER DESIGN PRESSURE OF INDIVIDUAL WINDOW OR MULLION OF INSTALLATION SHALL GOVERN.
- REFER TO EVALUATION REPORT# 7647 FOR MORE MULLION SPECIFICATIONS.

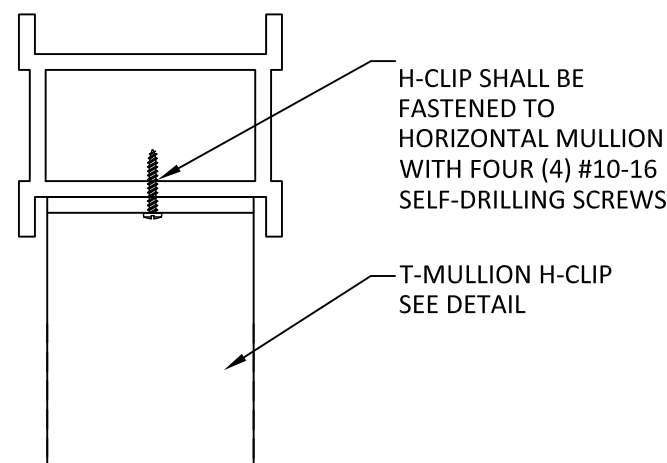

T-MULL CONNECTION

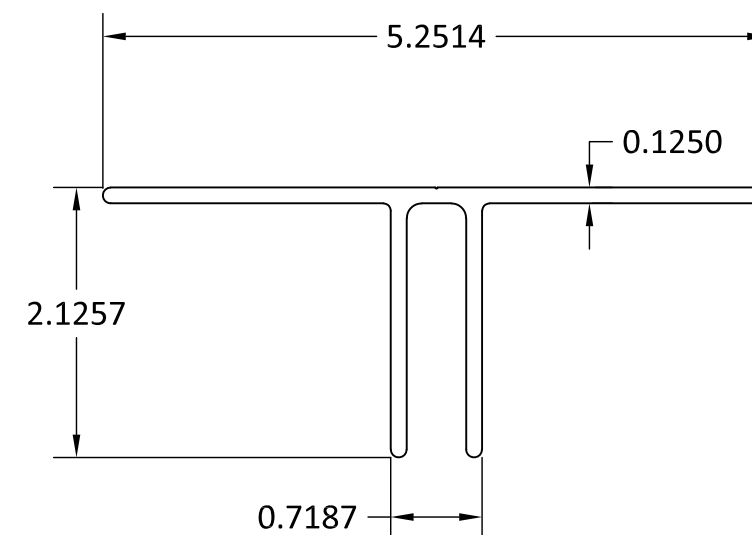

T-MULLION H-CLIP DETAIL

TITLE: SERIES 9100 HORIZONTAL MULLIONS (WZ3)/(IMPACT) SERIES 9100 MULL-HEAVY DUTY DP CHART & DETAILS

PREPARED BY: BUILDING DROPS, INC. 398 E. DANIA BEACH BLVD., STE. 338 DANIA BEACH, FL 33004 PH: (954)399-8478 FAX: (954)744-4738 WEB: www.buildingdrops.com

REMARKS	BY	DATE
MULLS & CLIPS REV.	MTJ	6/13
FBC 2014 UPDATE	SM	9/14
FBC 2017 UPDATE	HR	6/17
FBC 2020 UPDATE	LL	6/21

THE INSTALLATION DETAILS DESCRIBED HEREIN ARE GENERIC AND MAY NOT REFLECT ACTUAL CONDITIONS FOR A SPECIFIC SITE. IF SITE CONDITIONS CAUSE INSTALLATION TO DEVIATE FROM THE REQUIREMENTS DETAILED HEREIN, A LICENSED ENGINEER OR ARCHITECT SHALL PREPARE SITE SPECIFIC DOCUMENTS FOR USE WITH THIS DOCUMENT.

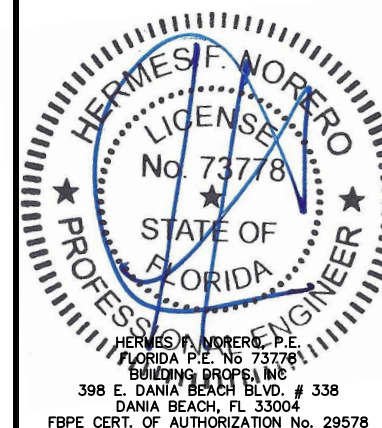

FL #: **FL15527**

DATE: **04.18.12**

DWG. BY: **MSS** CHK. BY: **HFN**

SCALE: **NTS**

DWG. #: **CRF012**

SHEET **5** OF 5